

## BUT DE BEACH HANDBALL COMPÉTITION

<b>TAILLE</b>	3 x 2 m
<b>POIDS</b>	35 kg
<b>MATIÈRE</b>	Aluminium/Acier
<b>STRUCTURE</b>	Tube Ø 80mm
<b>DESRIPTIF</b>	But aluminium / Acier galvanisé à structure ronde de 80 mm de diamètre, oreilles de support, base au sol et jambe de force en acier 32 mm, joints d'angle internes en aluminium et fourreaux.
<b>CONFORMITÉ</b>	NORME UNI-EN 749

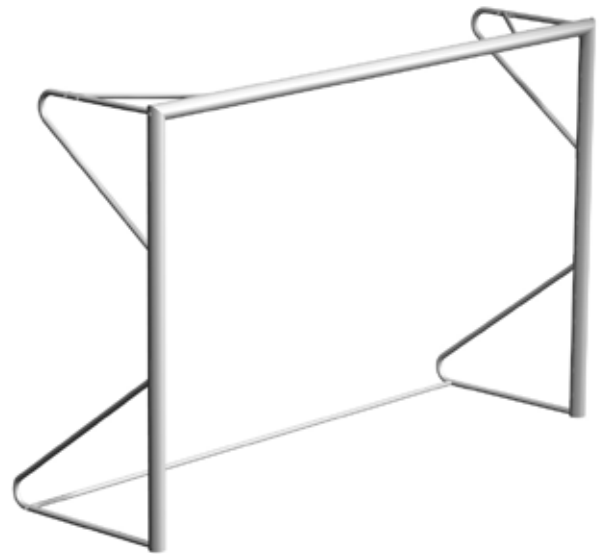

### CARACTERISTIQUES DU BUT

- 1** Structure du but : tube rond Ø 80mm
- 2** Dimensions du but : 3 x 2 x 0,80 x 1 m
- 3** Joints d'angle en aluminium
- 4** Fourreaux (400 mm de profondeur)
- 5** Crochets de fixation

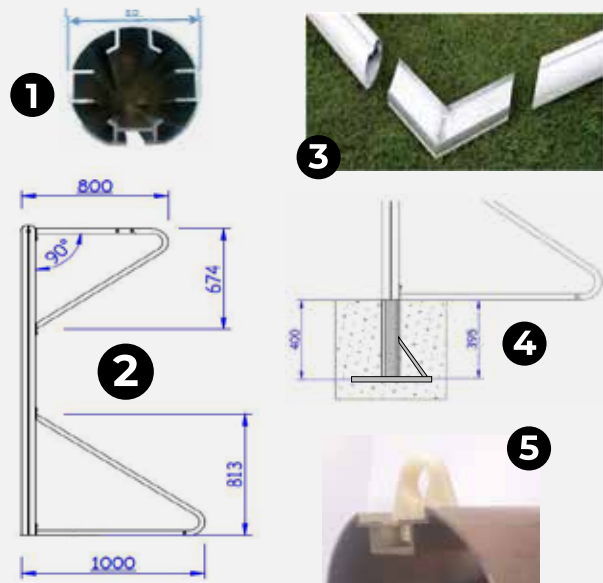

## BUT DE BEACH HANDBALL PERSONNALISABLE



En option : nous personnalisons vos buts selon les couleurs de votre ville, de votre club. Les filets sont également personnalisables.

Prise obligatoire Hors fourreaux prise au sol.

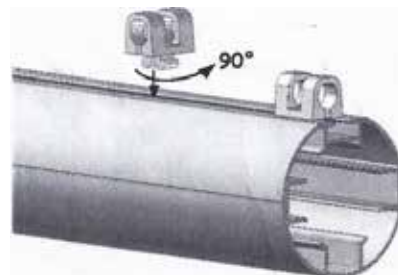
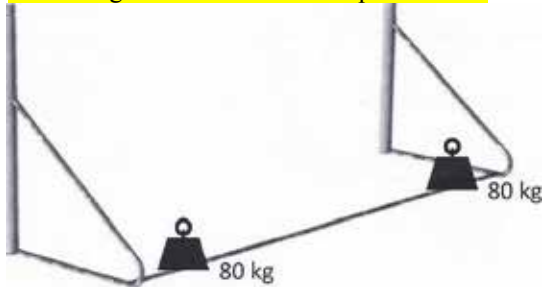

## CONTENU DE L'EMBALLAGE DU BUT

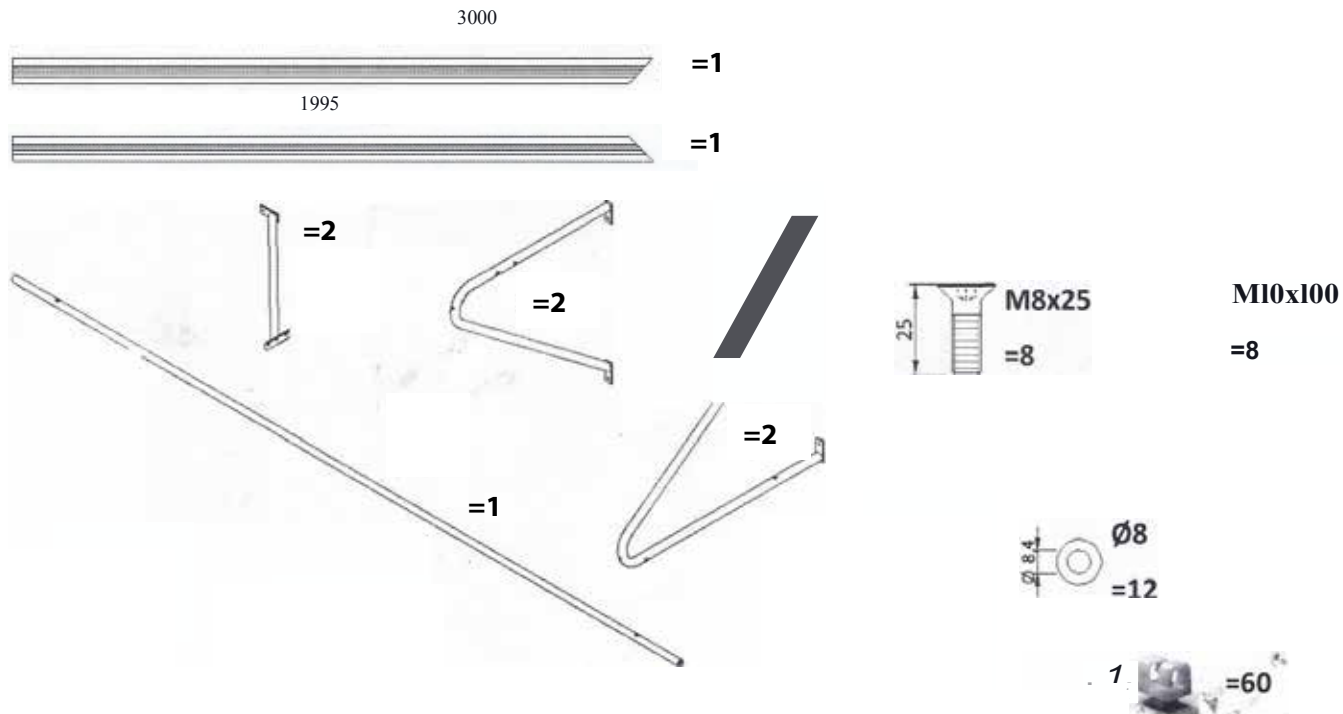

# NOTICE DE MONTAGE

## FICHE TECHNIQUE

EE

**Art.4642**



Nr PRO-GAM 001-19-ITA



FM 579557



**30,3 kg**

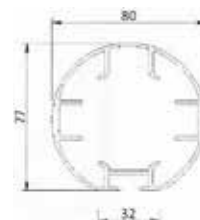
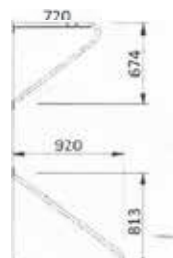
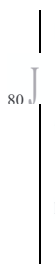

**3.00 x 2.00 m**

**EN 165/9 : 2018**

**CONFORME À LA NORME**

Cat. A3 - Type 3 - Cl. Mobile

1000 N

700 N

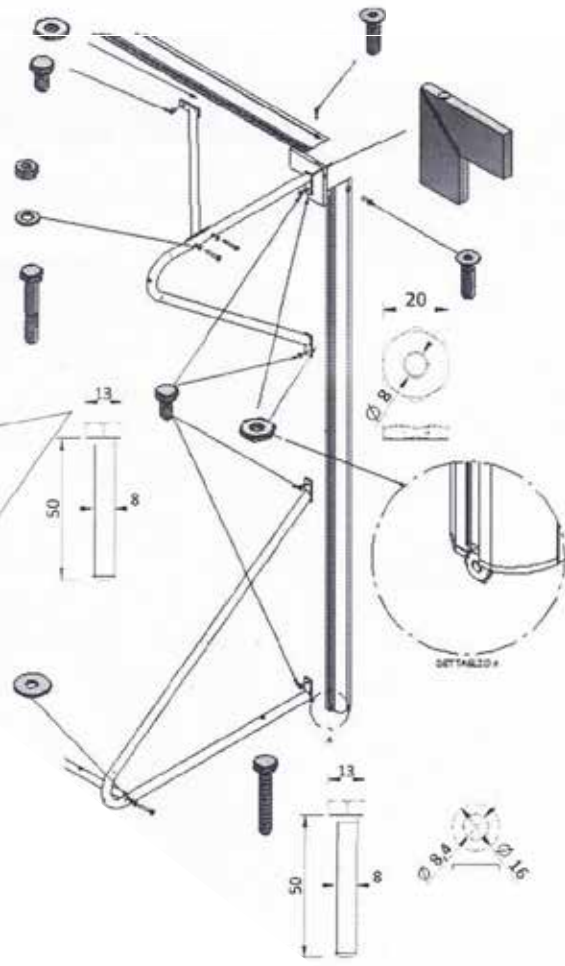
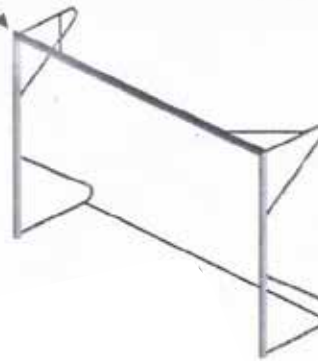
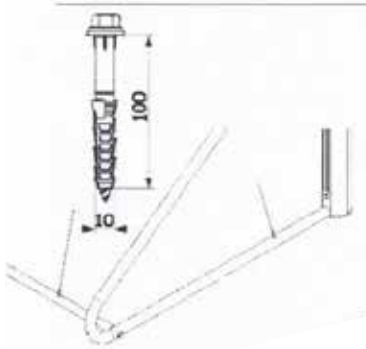
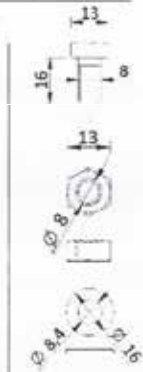
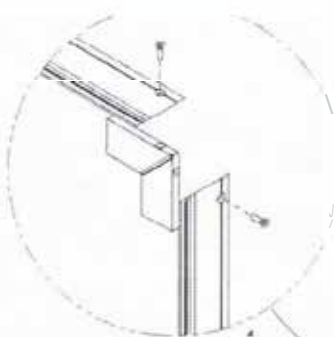

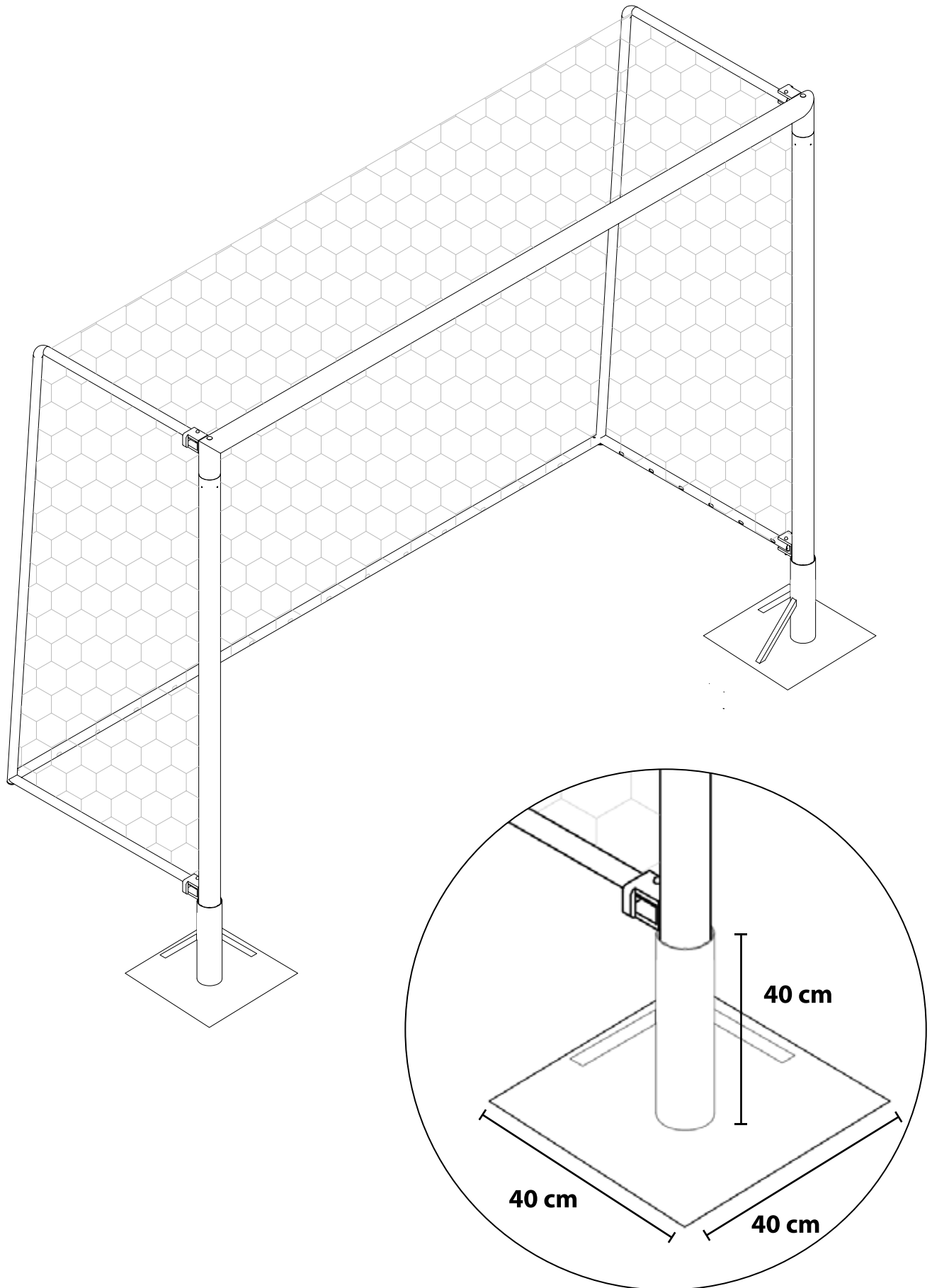



**Platine réalisée en Inox.**



# ANCRAGE SABLE LONGUE DURÉE (EN OPTION)

MASTER PLAN



4 PLATINES ACIER EP 3 MM  
TUBE BLEU : 50 X 50 X 2 MM  
TUBE VERT : 45 X 45 X 2 MM

PERCAGES DES TROUS DIAM 12 MM  
DANS TOLES ET TUBES

Poids :

Platines : 4 kg / pièce

Barre transversale de 2730 mm : 7,40 kg

Barres latérales de 1250 mm : 3,40 kg / pièce

## ANCRAGE SABLE LONGUE DURÉE (EN OPTION)

